

DUMPER D 25 PX

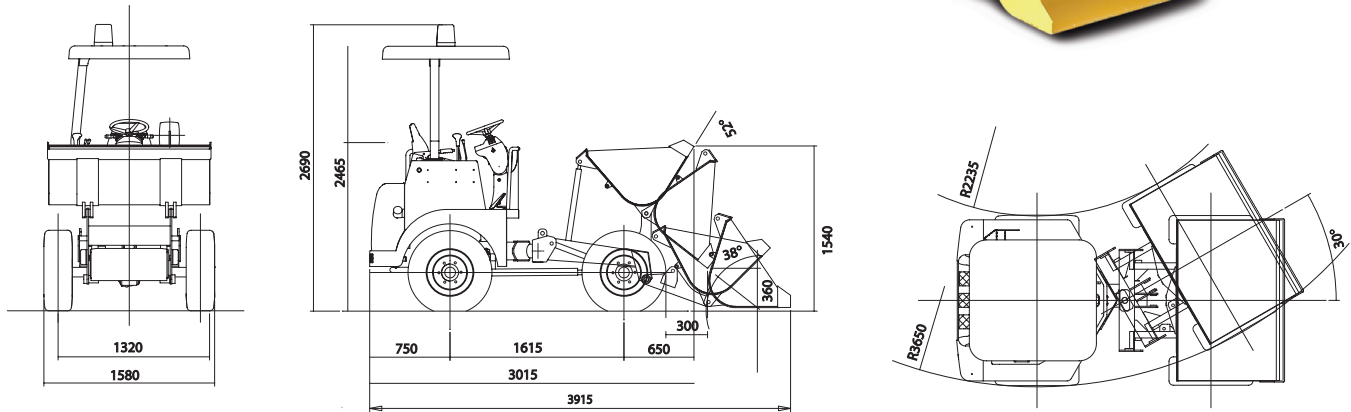

DIESEL ENGINE

Make and model YANMAR 3TNE82
Rated power 22,2 kW (30 HP)@ 3000 rpm
Torque, max 84.3 Nm No. of cylinders 3
Total displacement 1331 cu.cm Direct injection
Air filter with dry cartridge Water-cooled
Conforms with exhaust emissions Directive
97/68 CE and EPA regulations.

ELECTRICAL SYSTEM

Ignition motor 12V Alternator 12V - 15A Battery
12V-100Ah (450A) Electrical starting and stop
devices Cool starting device with termostating.

TYRES

Front and rear: 10.0/75-15.3

HYDRAULIC SYSTEM

Made up of dual hydraulic gear pump and distributor with lever and/or cloche control. Max payload: 35 Imp Max pressure: 150 bar Pressurized filtration system; the filter is replaceable from outside.

BRAKES SERVICE:

oil-bath disc brakes, housed inside the hubs, acting on all 4 wheels, fed by hydraulic independent brake pump.

FOUR WHEEL DRIVE

Hydrostatic transmission with variable displacement pump and dual displacement hydraulic motor with electro-hydraulic control for "slow-fast-reverse" modes. Air-oil exchanger for hydraulic oil cooling.

1st: from 0 to 9 km/h

2nd: from 0 to 20 km/h

Traction/weight ratio: 40%

AXLES

Front: self-bearing, with planetary reduction gears on wheel-hubs. Rear: self-bearing, with planetary reduction gears on wheel-hubs and block assembled transfer box in the differential housing. drum type on the front axle; mechanical lever controlled.

STEERING

Hydrostatic fed by independent pump with steering-wheel control. Displacement 4,5 cu.cm/rev. Working pressure, max: 100 bar. Controlled through steering cylinder acting on central articulation. Inside wheels min. steering radius: 2350 mm Outside wheels min. steering radius: 3650 mm Total steering radius: 60° (chassis articulation)

CHASSIS

Electro-welded steel structure, HEAVY DUTY articulation in central line with high resistance steel pressed dual pin. Total oscillation angle: 24° Hydraulic control of skip dumping by double-acting hydraulic cylinder. Loading bucket: front skip can be used also as loading bucket. Material load is made in the same way of a conventional articulated loader.

DRIVER'S PLACE

Rational and ergonomic, easy access, central and elevated position, with excellent visibility. Anatomically designed seat with vertical and longitudinal regulation. ROPS-FOPS operator's canopy. Steering column with instrumentation dashboard and inclination adjustment of the steering wheel.

SERVICE CAPACITIES

Fuel (diesel): 30 litres

Hydraulic oil: 48 litres

Engine oil: 3,6 litres

WEIGHTS AND CAPACITIES

Weight in working conditions: 1670 kg

Max skip payload: 870 kg

Skip capacity, struck: 500 litres

Skip capacity, heaped (SAE std): 650 litres

DIMENSIONS

Min. move length 3015 mm

Max width 1590 mm

Max move height 2465 mm

Inside steering radius 2350 mm

Rear overhang angle 37°

Ground clearance (under differentials)

260 mm