

FIORI

D 70

The ideal dumper for any use:

- where places are narrow through its 4 wheel steering
- where is not possible to U-turn through the 180° pivoting driver's seat
- where operators are exigent and want to have an efficient and comfortable machine through the hydrostatic transmission
- if there is somewhere you can't go to, through Fiori dumpers now you can

Max payload 7 ton.
Heaped capacity 4,0 cu.m.
Diesel engine 87 Hp



Minimum transfer length:	4,600 mm
Max width:	2,200 mm
Max transfer height:	2,730 mm
Front pitch:	38°
Ground clearance (below differentials):	350 mm

FIORI SPA



Via per Ferrara, 7 41034 Finale Emilia (Modena-Italia)
Tel. +39(0535)780089-92357 - Telefax +39(0535)90960
Internet: www.fiorigroup.com e-mail: fiori@fiori.cc



DIESEL ENGINE

Make/Type: PERKINS 1104C-44 "FASTRAM" direct fuel injection turbo aspirated diesel engine.
Max power 64 KW (87 HP) at 2,400 rpm.
Max torque 302 Nm at 1,400 rpm.
N 4 cylinders. Displacement 4,400 cc.
Bore and stroke 105 x 127 mm.
Dry air cartridge filter.
Water-cooled.
Conforms with exhaust emission directive 97/68 CE (STAGE 2) and EPA regulations.



HYDRAULIC SYSTEM

Gear pump - 1 way control valve
Max flow-rate: 47 l/min
Max pressure: 180 bar
Oil filter replaceable from the outside.
Pressurized closed circuit suction system.



ELECTRICAL SYSTEM

Starter motor 12V - 2.8 kW.
Alternator 12V - 55 Ampere.
Battery 12V - 132 Amp/h - (600 Amp).
Electrical engine ignition/stop device.
Plug heater cold starting device.



BRAKES

SERVICE AND EMERGENCY BRAKES:
disc-brakes in oil bath housed inside the hubs, acting on all 4 wheels, fed by independent pump on double circuit.
PARKING BRAKE:
Drum brake on front axle with lever mechanical control.



FOUR-WHEEL DRIVE

"Automotive" hydrostatic transmission with variable-displacement pump and automatic variable-displacement hydraulic motor.
Drive enable safety device on the accelerator pedal.
Air/oil heat exchanger for oil cooling.
Mechanical 2-speed gearbox (with electrohydraulic selector for working speed and drive speed), enbloc with the rear axle.

GEAR: Total:	4 FORWARD:	4 REVERSE:
1 st	0 - 3.3 Km/h	0 - 3.3 Km/h
2 nd	0 - 8.0 Km/h	0 - 8.0 Km/h
3 rd	0 - 10.0 Km/h	0 - 10.0 Km/h
4 th	0 - 25.0 Km/h	0 - 25.0 Km/h

Drive/weight ratio: 50%



AXLES

FRONT: oscillating ($\pm 75^\circ$), steering and bearing type with planetary reduction at the wheel hubs.
REAR: steering, bearing type with planetary reductions at the wheel hubs.



TYRES

Front and rear tyres 12.5/18



STEERING

Hydrostatic (ORBITROL type), fed by independent pump, with steering wheel control.
Swept volume: 100 cc
Max working pressure: 150 bar
Power steering pump flow rate 21 l/min
4-wheel steering by means of n°2 double steering cylinders acting as connection rods.
In-cab steering mode selector.
Available modes:
2- wheel steering/4- wheel steering/"Crabbing".
Minimum inside wheel turning radius: 2,020 mm
Minimum outside wheel turning radius: 3,330 mm

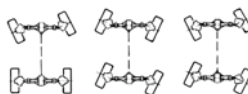

2WS CRABBING 4WS



CHASSIS

Electrically welded high-tensile steel chassis.
Hydraulic control for skip lift up by means of hydraulic double-action jacks.

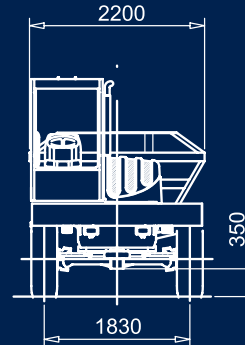
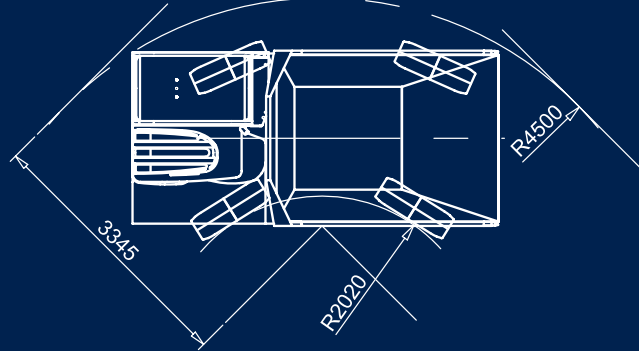
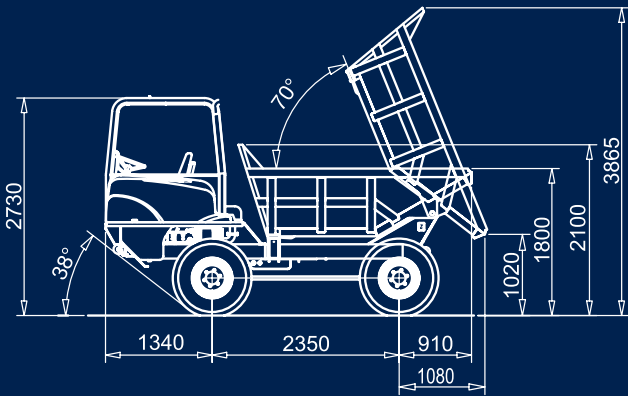

ALL SPECIFICATIONS ARE INDICATIVE AND MAY BE CHANGED WITHOUT PRIOR NOTICE.
PHOTOS SHOW OPTIONAL ACCESSORIES.



SERVICE CAPACITIES

Fuel tank:	90 litres
Total hydraulic oil:	100 litres
Diesel engine oil:	7,5 litres



WEIGHTS AND CAPACITIES

On-road set-up with cab roof:	4,100 Kg
Load-carrying capacity (at max speed):	7,000 Kg
Skip capacity struck:	3,000 litres
Skip capacity heaped (SAE):	4,000 litres



DRIVER'S PLACE

Open safety ROPS cab.
Swivel, mounted on a ball-bearing center-plate; anatomically designed, fully adjustable seat with safety belt.
Instrumentation: engine ignition/off switch; cold starting device; hour meter.
Warning lights: engine coolant temperature, hydraulic filter clogged, preheating, generator charge, direction indicators, clearance lights, low-beams, engine oil pressure, fuel level, beacon, "warning". Headlight and direction indicators switch.
Fuses and relays box (water proof).