

Concrete mixer

DB 110

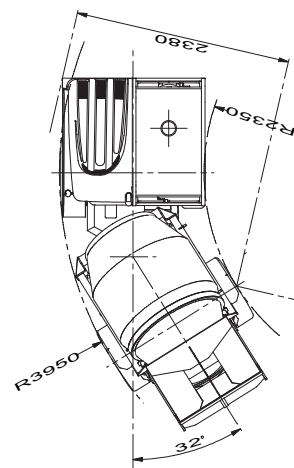
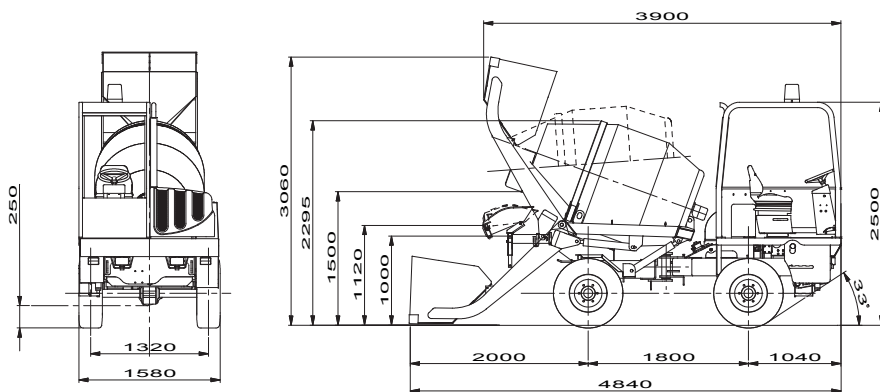

Diesel Engine

Mark PERKINS diesel 403C-15 (34 Hp)
Reg. Power 24,4 kW (33 Hp) a 2.800 rpm
Max torque 96 Nm
Cylinders nr. 3 - Displacement 1.496 cc
Dry air cartridge filter
Water-cooled - Indirect fuel injection
Emissions 97/68 CE and EPA

Electrical system

Alternator 12V - 45 A
Battery 12V - 80 AH (400 A)

Four-Wheel drive

hydrostatic "automotive" a 2 speed
speed: 2 forward - 2 reverse
1a 11,0 Km/h - 11,0 Km/h
2a 19,0 Km/h - 11,0 Km/h
Drive/Weight ratio: 31%

Axle

Front: bearing, oscillating ($\pm 7^\circ$) axle
with planetary final drive on wheel hubs
Rear: bearing axle with planetary final
drive on wheel hubs and distribution
frame block assembled on differential box

Brakes

SERVICE: disc-brakes in oil bath
housed inside the hubs, acting on all 4 wheels,
fed by hydraulic independent brake pump.
PARKING AND EMERGENCY: lever-controlled
drum brake on front axle

Tyres

Front and rear tyres 10.0/75 - 15,3

Steering

servoassisted steering by load-sensing
power-steering acting on 2 hydraulic jacks;
Minim. inner wheel turning radius: 2.350 mm

Chassis

High resistance chassis in steel ST52
Max hopper off-loading height: 1.500 mm
Max chute off-loading height: 1.120 mm
Min. chute off-loading height: 1.000 mm

Cab

Open safety ROPS - FOPS with swivel 180° driving
post Lights and direction indicators for road
circulation

Hydraulic system

Gear pump - 3 way control valve
and aluminium oil cooling
Max flow-rate: 30 l/1'
Max pressure: 170 bar

Water system

Fast suction water pump, self-priming
rotor type Max flow-rate: 250 l/1'
Max head: 2.0 bar
Tank capacity: 185 l.
Water pump control located in cab
and on ground, suction control from
ground with fast coupling.

Drum

Drum rotated by hydrostatic transmission with
variable flow pump with electrohydraulic control
located in the cab and in machine back side.
Drum rotation speed: from 0 to 20rpm

Drum volume: 1.600 l
Max concrete yield: 1.100 l
Nr. 1 discharge chute extensions

Loading bucket

Load bucket capacity 320 l.
Number of bucket required per load 4

Service refill capacities

Fuel tank: 40 l.
Hydraulic oil tank: 60 l.

Weights

On-road set-up weight: 3.100 kg.
Max homologated weight: 5.700 kg.
Homologated load-carrying weight: 2.600 kg.