

CONCRETE 4x4 TRANSPORT DELIVERY SYSTEM

FIORI®

DB560T



FIORI DRIVE SYSTEM



CONCRETE 4x4 TRANSPORT DELIVERY SYSTEM



DB560T

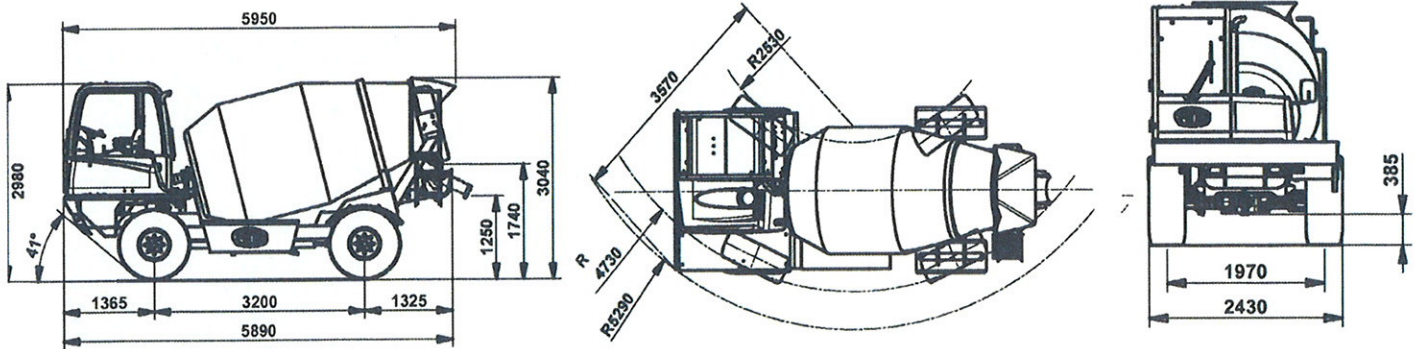

DIESEL ENGINE

Mark PERKINS diesel-turbo
aftercooler 1104D-44TA
Max Power 86,5 Kw - (118 HP)
Reg. Power 83 kW (113 HP) a 2200rpm
Max torque 418 Nm a 1400rpm
Cylinders nr. 4 - Displacement 4.400 cc
Dry air cartridge lter
Water-cooled - Direct fuel injection aftercooler
Emissions 2004/26/CE STAGE 3 and EPA

ELECTRICAL SYSTEM

Alternator 12V - 55 A
Battery 12V - 132 AH (600 A)

FOUR WHEEL DRIVE

high pressure hydrostatic "automotive"
at 2 automatic speeds,
mechanical 2 speeds gearbox with
electrohydraulic control.
Speeds: 4 forward - 4 reverse
1a 4,6 Km/h - 4,6 Km/h
2a 10,6 Km/h - 10,6 Km/h
3a 13,7 Km/h - 13,7 Km/h
4a 30,0 Km/h - 30,0 Km/h
Drive/Weight ratio: 38%

AXLE

Front: bearing, oscillating ($\pm 6^\circ$) steering with
planetary drive on wheel hubs
Rear: bearing, steering with planetary drive on wheel hubs and gearbox embloc with
differential housing.

BRAKES

SERVICE AND EMERGENCY BRAKES:
disc-brakes in oil bath housed inside the
hubs, acting on all 4 wheels, feeded by pump
independent twin circuit.
PARKING: Internal negative disc-brakes in oil bath
with electrohydraulic control on the frontal axle

TYRES

Front and rear tyres: 18 - 19,5

STEERING

Load-sensing servoassisted; 4 steering wheels
In-cab steering mode selector: 2 steering
wheels/4 steering wheels/crabbing
Minim. inner wheel turning radius: 2.590 mm

CHASSIS

Tubular chassis made
in high-resistance ST52 steel
Max hopper off-load height: 1.750mm
Max chute off-load height: 1.250mm

CAB

Closed safety ROPS - FOPS with heating and
180° swivelling driving post.
Lights and direction indicators for road circulation

WATER SYSTEM

"Auto-suction" water pump
Max Flow-rate: 300 l/1'
Max head: 2.0 bar
Tanks capacity: 300 l.
Water pump control located in cab and on the
ground. Suction control from the ground with
fast coupling pipes

DRUM

Drum rotated by hydrostatic transmission with
variable flow pump with electrohydraulic control
located in the cab and in machine back side with
MIX CONTROL . Immitesimal control.
Discharge chute control from the ground and
movable chute support.
Drum rotation speed: from 0 to 21 rpm
Geometrical Drum Volume: 7.450l
Max concrete yield: 5.500 l
Nr. 3 discharge chute extensions

SERVICE REFILL CAPACITIES

Fuel tank: 95 l. - polyethylene (PER)
Hydraulic oil tank: 90 l.

WEIGHTS

On-road set-up weight: 5.200 kg.
Max weight: 18.000 kg.

SEMCO EQUIPMENT SALES
55-63 KURRAJONG RD
LOCKED BAG 20
ST MARYS NSW 2760

