

TB108

FULLY HYDRAULIC COMPACT EXCAVATOR



TAKEUCHI

TAKEUCHI

THE HIGHLY TB108 MICRO



**EASY ACCESS &
MAINTENANCE**



**EXTENDING
TRACK WIDTH**

**AVAILABLE
WITH
DEDICATED
TRAILER**

The TB108 is our smallest excavator, weighing in at just 835Kg. It's micro dimensions enable it to pass through a normal doorway and it's unique extending hydraulic tracks can then be adjusted to add extra stability to its working dig depth of 1680mm.

Complete with 3 buckets and available with a dedicated trailer- just add a Takeuchi breaker or an auger and it's ready for work.

Legendary Japanese build quality means reliability second to none.



VERSATILE EXCAVATOR



STANDARD FEATURES

- Hydraulically expandable track frame
- Two speed travel
- Adjustable width Dozer Blade
- Two-way auxilliary hydraulics plumbed to dipper arm
- 180 degree independent boom swing
- Lockable tilt back steel engine cover
- Cast iron wrap around protective counterweight
- Standard rubber tracks
- Planetary final drives
- Precise response proportional main control valves
- Safety lockout lever for travel & operating controls
- Retractable seat belt
- Automatic fuel bleed system
- Recessed sight guages for fuel and hydraulic oil
- Boom mounted work light
- Engine oil 'Safedrain' system
- Folding ROPS bar

OPTIONS

- 3 Year Warranty
- TKB51 Hydraulic Breaker
- Auger

FITS THROUGH A STANDARD DOORFRAME



TB108

OPERATING RANGE

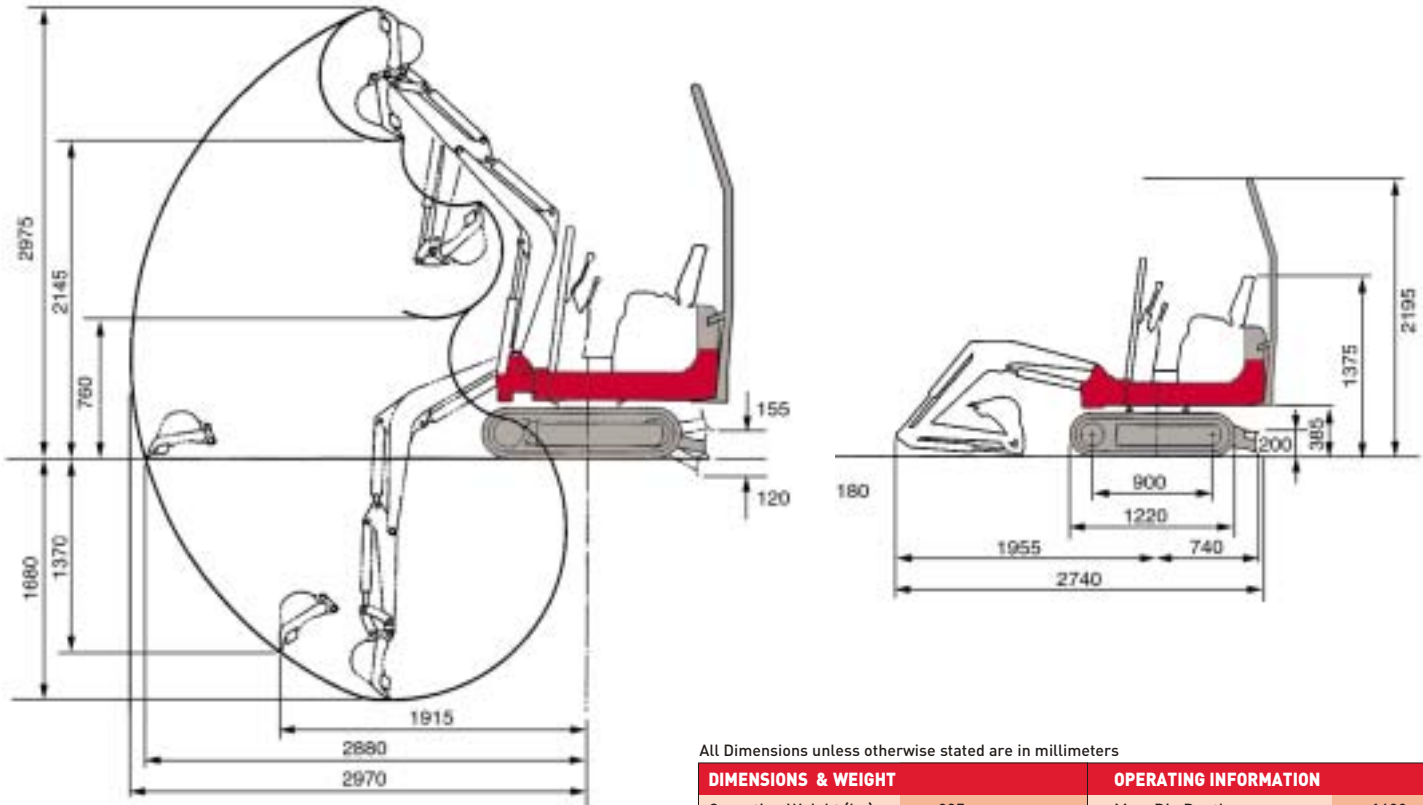

In accordance with our established policy of constant improvement, we reserve the right to amend these specifications at any time without notice. Photographs shown may feature non-standard equipment.

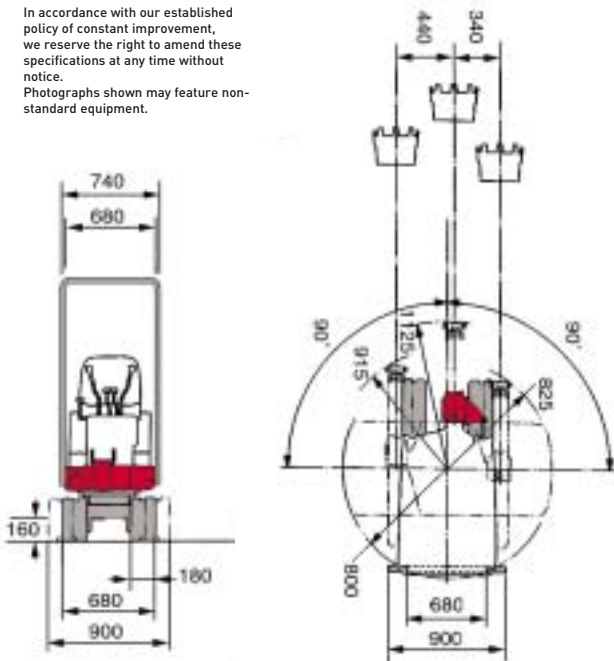

All Dimensions unless otherwise stated are in millimeters

DIMENSIONS & WEIGHT		OPERATING INFORMATION	
Operating Weight (kg)	835	Max. Dig Depth	1680
Length (transport)	2740	Max. Dump Height	2145
Width with canopy	740	Max. reach at ground level	2880
Width with fold down bar	705	Max. Vertical Dig Depth	1370
Height with canopy	2140	Max. Bucket Dig Force (Kn)	10.2
Height with bar raised	2150	Max. Arm Dig Force (Kn)	6.6
Height with bar down	1390		
Ground Clearance	160	UNDERCARRIAGE	
Min front swing radius (90° boom swing)	825	Traction Motor	Axial Piston
Tail swing radius	800	Traction Drive	Planetary
Dozer Blade (wxh)	680-900x200	Traction Brake	Disc
		Track Width	180
		Ground Contact Length	900
		Ground Pressure (kpa)	22.5
		Travel Speed (K/ph)	2.0/3.9
		Maximum Gradeability	30°
ENGINE		HYDRAULIC SYSTEM	
Make/Model	Yanmar2TNE68	Set Pressure (bar)	160
Rated Output/RPM	6.8kW/2400	Pump Type	Gear x2
Maximum Torque	33Nm	Hydraulic Flow (l/min)	10.7 x2
Cylinders/Displacement	2/523cc	Auxiliary Flow (l/min)	22
Electrical System	12volt 34amp	CAPACITIES (l)	
SWING SYSTEM		Hydraulic system	15.6
Boom Swing angle (L/R)	90°/90°	Fuel tank	9.4
Slew Speed (rpm)	9	Engine Lubrication	1.6
Slew Motor	Orbital	Cooling System	2.5

TAKEUCHI

Takeuchi Mfg (UK) Ltd, Lynroyle Way, Rochdale, Lancs OL11 3EX Tel: 01706 657722 Fax: 01706 657744
e-mail: sales@takeuchi-mfg.co.uk www.takeuchi-mfg.co.uk

Southern Office at Thatcham, Newbury Tel: 01635 877 196 Fax: 01635 877 195