

# TB23R

SHORT TAIL SWING COMPACT EXCAVATOR



**TAKEUCHI**

SHORT TAIL

# INTRODUCING T - MADE FOR TI



**EASY ACCESS**



**SUPERB  
OPERATOR  
COMFORT**



# THE NEW TB23R TIGHT CORNERS



**NEAR ZERO  
TAILSWING**

Near zero tailswing is what makes the new TB23R the ideal machine when you're really up against it.

Weighing in at 2600kg (Cab) and 2415kg (Canopy) it's a mid sized machine capable of offset dig functions to left and right and in a variety of situations.

Featuring either a comfortable cab or TOPS/FOPS canopy, two speed travel, a low noise EPA emission compliant engine and all the other features you'd expect in a Takeuchi

excavator, the TB23R, like all our machines, embodies the perfect combination of what today's contractors want - reliability and operator comfort.

All Takeuchi machines are manufactured in Japan - renowned for precision engineering expertise and legendary build quality - so you can be safe in the knowledge that you've got a machine you can rely on.



**TOPS/FOPS CANOPY**

- Wider Operator's compartment
- Exceeds latest emission standard
- Low noise engine
- Easy Access & Maintenance

# TAKEUCHI

# TB23R

## STANDARD FEATURES

- Short tail swing
- Offset Dig LH/RH 80°/50° Canopy 65°/50° Cab
- Two speed travel
- TOPS/FOPS four post canopy or Cab
- Emergency engine shutdown/return-to-idle system
- Electronic engine monitoring system
- Automatic fuel bleed system
- Variable displacement piston pumps
- One touch engine decelerator
- Safety lockout lever for travel and operating controls
- Remote slew lubrication system
- Two-way auxiliary hydraulics plumbed to dipper arm
- Spring applied, hydraulically released disc type slew and parking brakes
- Precise response, proportional main control valves
- Simultaneous operation of cab swing and two digging functions with no reduction in speed
- Straight travel with simultaneous operation of digging and swing functions
- Cushioned main boom, arm and swing cylinders
- Hydraulic oil cooler
- Protective routing of bucket and arm cylinder hydraulic hoses
- Pilot operated joystick controls with armrest
- Main boom cylinder guard
- Low noise level and EPA exhaust emission compliant engine
- Engine oil 'Safedrain' system
- Fully adjustable suspension seat with retractable seat belt
- Vandalism protected lockable fuel tank and engine compartment
- Lockable operator's manual and storage compartments
- Short pitch rubber tracks

## OPTIONS

- TKB101 Hydraulic Breaker
- Steel tracks

In accordance with our established policy of constant improvement, we reserve the right to amend these specifications at any time without notice. Photographs shown may feature non-standard equipment.

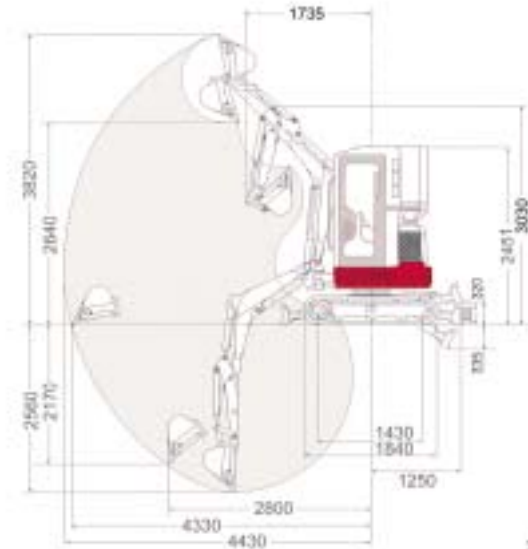

operating range - long arm

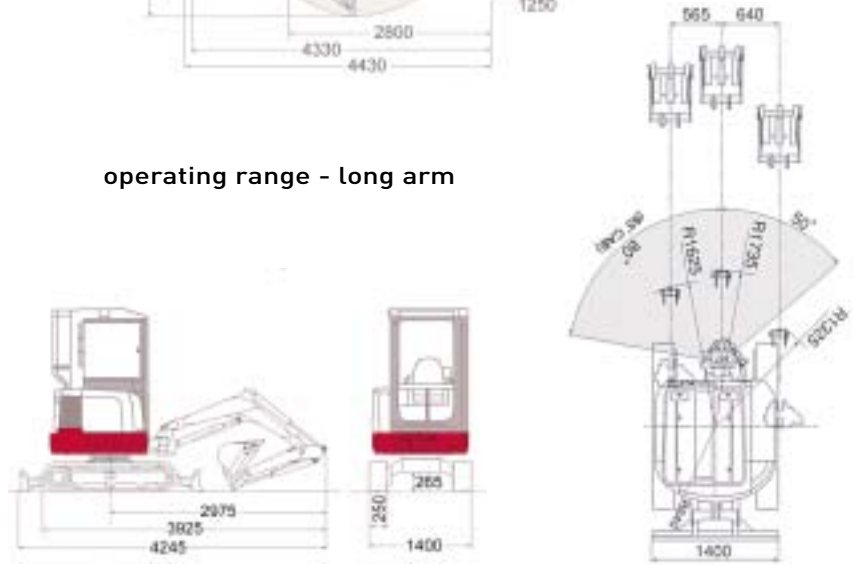

All Dimensions unless otherwise stated are in millimeters. CB = Cab CY= Canopy

DIMENSIONS & WEIGHT		OPERATING INFORMATION		CB	CY
Operating Weight (kg)	2600 CB/2415 CY	Max. Dig Depth	2560	2560	
Length (transport)	3926	Max. Dump Height	2640	2980	
Width	1400	Max. reach at ground level	4430	4430	
Height	2451 CB/2430 CY	Max. Vertical Dig Depth	2170	2170	
Ground Clearance	265	Max. Bucket Dig Force (Kn)	19	19	
Min front swing radius (80° boom swing)	840	Max. Arm Dig Force (Kn)	12.6	12.6	
Rear Slew radius	840	<b>UNDERCARRIAGE</b>			
Dozer Blade (wxh)	1400x300	Traction Motor	Axial Piston		
Blade Range Up/Down	320/335	Track Width	250		
<b>ENGINE</b>		Ground Pressure (kpa)	33.3		
Make/Model	Yanmar/3TNV76	Travel Speed (K/ph)	2.4/4.2		
Rated Output/RPM	13.9kW/2300	Maximum Gradeability	30°		
Maximum Torque	68.1Nm	<b>HYDRAULIC SYSTEM</b>			
Cylinders/Displacement	3-4 /3345cc	Set Pressure (bar)	210		
Electrical System	12volt	Pump Type	Variable(P1+P2)+Gear(P3+P4)		
<b>SWING SYSTEM</b>		Hydraulic Flow (l/min)	23x2+14.7+9.4		
Boom Swing angle (L/R)	65°/50° CB/80°/50° CY	Auxiliary Flow (l/min)	37.7		
Slew Speed (rpm)	9.6	<b>CAPACITIES (l)</b>			
Slew Motor	Axial Piston	Hydraulic system	25		
Slew Brake	Disc	Fuel tank	30		
		Engine Lubrication	3.4		
		Cooling System	3.5		

# TAKEUCHI

Takeuchi Mfg (UK) Ltd, Lynroyle Way, Rochdale, Lancs OL11 3EX Tel: 01706 657722 Fax: 01706 657744  
e-mail: sales@takeuchi-mfg.co.uk www.takeuchi-mfg.co.uk

Southern office at Thatcham, Newbury Tel: 01635 877 196 Fax: 01635 877 195